

Owner's Instructions



Part No. : L3930

3:1 HIGH VOLUME OIL PUMP

Read the following precautions and instructions before you begin assembly or use. Failure to comply with these instructions could result in personal injury or property damage. Keep these instructions in a convenient location for future reference.

Important Note

The guarantee will be void if the pump has been altered in any way.

Profile

Oil pumps can be used to transfer lubrication oil, and anti-freeze liquids. This manual is applicable only to the models listed above, please confirm your pump is included.

Specifications

Operating Pressure (psi / bar)	70-115 / 5-8
Max. Fluid Pressure (psi / bar)	348 / 24
Air Consumption (CFM L/min)	5.0 / 140
Capacity (Gallon/min / L/min)	7.5 / 28
Air Inlet Connection	1/4" quick plug / 1/4" NPT female
Oil Delivery Connection	Male 1/2"
Max. Viscosity Oil Delivered	SAE 140
Temperature Oil Delivered (F / C)	15-120° F / 10-50° C
Noise Level (dB)	82

Troubleshooting

Problem	Possible Causes	Solutions
The pump continues to operate after the gun trigger has been released	1. There is an oil leak at some point of the circuit 2. Valve sets (part No.39, 40, 41) close incorrectly due to dirt or wearing.	1. Check and tighten unions. Repair the leak. 2. Replace damaged parts.
Reduction of the oil delivery, or reduced pressure in the oil delivery.	1. Silencer (53) dirtied 2. Blocked at some point of the oil circuit 3. Ball valve set (35, 36) closes incorrectly due to dirt or wearing.	1. Clean or recharge silencer 2. Use clean oil 3. Replace damaged parts
Air loss through the air exhaust	1. The sliding valve (4) does not close properly. 2. Broken press piece (5) 3. Damaged O-ring (21, 21) 4. Damaged piston (50) 5. Broken spring (18)	1. Disassemble and clean. Replace in case of damage. 2. Replace damaged parts
Oil leaks through the air exhaust	Seal set (45, 46, 47) damaged	Replace damaged parts

If the pump has anything wrong, please contact dealer or their technical support

Storage and Maintenance

Pumps are delivered in appropriate carton boxes. Packaging material should be properly disposed. Handling and storage of the new pump do not require any special procedures.

However after the pump has been used, empty the used oil in the suction tube into an appropriate container. This is done by overturning the pump. The dust in compressed air can slow down and even block the motor cylinder. The following steps may prevent this from happening:

- 1) Let in 50 gram of air tool oil into the air inlet hole weekly, operate the pump for several minutes after filling lubricator.
- 2) Turn on the pump for several minutes until moving parts is fully lubricated.
- 3) You may repeat the above operation if necessary.
- 4) The above steps should be carried out on a weekly basis.

For the pumps that are attached with compressed air treatment equipment, please empty the water retained in the reservoir of the filter-purger frequently. For the pumps that are attached with a lubricator, please pay close attention to the lubricator's oil level and refill with SAE 20, SAE 30 or antifreeze oil for extreme conditions when necessary.

Note:

The user should perform only routine maintenance operations (such as filters, silencers, cleaning...) with the pump in order not to damage it or compromise its safety. Contact our sales or service center when the pump needs further maintenance.

General Safety Regulations

When the pump is connected to the compressed air supply:

1. The compressed air must be filtered to avoid dust and moisture into pump
2. The max compressed air pressure must not exceed 0.8Mpa/120psi
3. To deliver oil, pull the trigger on the delivery pistol; delivery stops when the trigger is released but the whole system remains under pressure
4. Position the gun so that the circuit can't open accidentally. Otherwise oil could leak onto the ground
5. Never point the pistol at people or object.
6. Pull the gun trigger
7. Always cut off the air supply after use so that oil can't leak out in case one of the pump's components should break
8. Use only original spare parts in case the pump has to be repaired or its components have to be replaced
9. Empty all the oil from the pump in case it has to be disposed of
10. When not in use, turn off compressed air to stop pump
11. Do not use the pump near open flames. Do not smoke during this operation
12. Wear oil-proof gloves
13. Do not throw the oil away. Used oil has to be disposed of according to environmental regulations

14. The pumps can be used only to deliver lubricants, used oil or antifreeze liquids. Do not use the pump for any other substance

How to Use

Directly Fitted Pump into the Drum

1. Insert the suction tube of pump into the drum and secure with ring nut, suitable for commercial drums with 2" bung opening.
2. Fit a oil delivery hose for oil outlet of the air operated pump using only high quality hoses (normally 1/2" by means of 3/4" fitting).
3. Oil delivery pistol NPT threaded: Connect delivery hose with delivery pistol using suitable pipe fittings.
4. Air inlet connection is 1/4" quick plug (or 1/4" NPT female) in all versions. Compressed air connection (to be supplied by the customer) should be done using suitable plumbing.
5. A pressure regulator to keep the pump's working pressure at the best possible level (max 70-115 psi / 5-8 bar) is recommended between the pump and the compressed air line
6. A valve can enable the operator to stop the pump at any given moment by cutting the air supply off between the pump and the compressed air line
7. Slowly open the compressed air valve that feeds the pump. It will start to operate, priming automatically and filling the feed circuit with oil. The pump is now prepared for its usual function.

Code	Name
1	Oil pump
2	Bung adapter
3	Oil pistol
4	Hose with fitting
5	Air hose with quick coupling
6	Drum
7	Filter, pressure regulator and lubricator

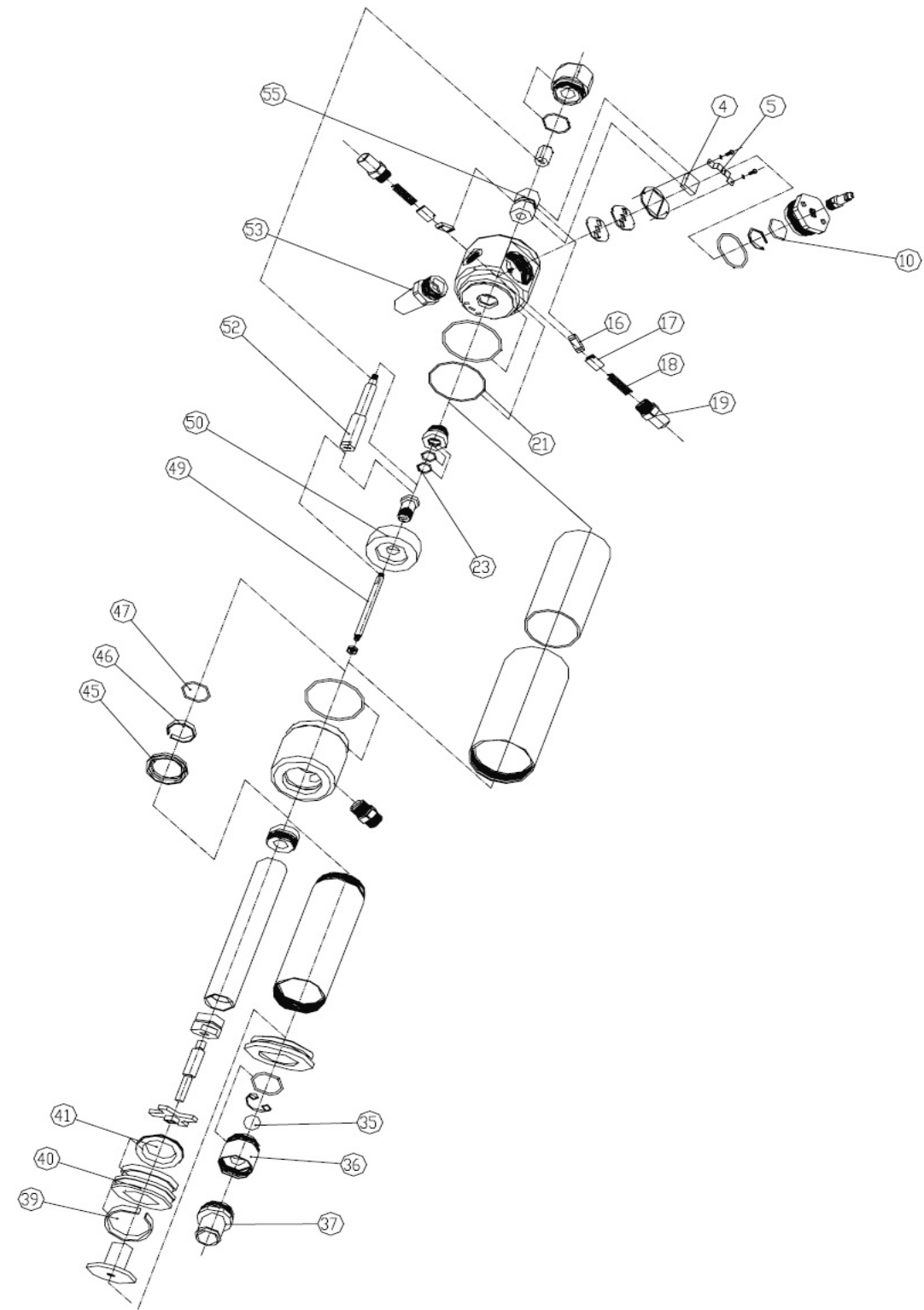
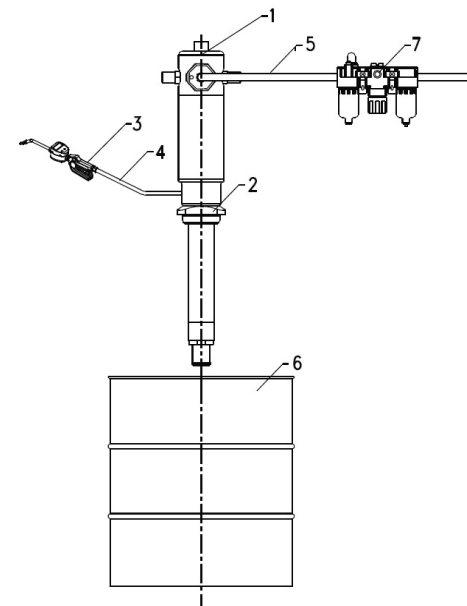

3:1 Oil Pump Repair Part Kit RP009050

Ref	Description	Q'ty
4	Slider	1
5	Press piece	1
10	Silencer	1
16	Trip shoe guide	2
17	Spring seat	2
18	Spring	2
19	Spring shell	2
21	O-ring	1
23	O-ring	2
35	Ball	1
36	Valve seat	1
37	Filter	1
39	U seal	1
40	Small piston	1
41	O-ring	1
45	O-ring	1
46	U seal	1
47	O-ring	1
49	Shaft	1
50	Piston	1
52	Bracket	1
53	Silencer	1
55	Slider	1

WARRANTY*

LEGACY MANUFACTURING COMPANY ("LEGACY") warrants that this equipment will be free from defects in material and workmanship for a period of five (5) years from the date of purchase, under normal use.* LEGACY'S sole obligation under this warranty is limited to replacing or repairing, free of charge, any equipment that proves to be defective under normal conditions and use according to the recommendations of LEGACY. To obtain repair or replacement, the equipment must be shipped to a LEGACY authorized Warranty and Service Center during the warranty period, transportation charges prepaid, with proof of date of purchase. In the event of repair or replacement, the warranty period shall not be extended beyond the original warranty period.

* If this equipment contains a hose, the hose is warranted for ninety (90) days only. The remaining portions of this equipment are warranted for five (5) years, as described above. While necessary maintenance or repairs on your Legacy equipment can be performed by any company, we recommend that you use only authorized Legacy service centers. Improper or incorrectly performed maintenance or repair voids this warranty. Contact us at service@legacymfg.com or www.legacymfg.com for ordering, installation instructions.