



Part No.: L3950K275

5:1 Ratio Heavy Duty Pump

1 Product Summary

1.1 Purpose

These pumps mainly provide power for oil transportation. Any other use might cause safety problems and parts damage, fire explosion, oil spark or serious skin injection.

1.2 Safety

Warning: You may be serious injury or death if you do not follow the instructions.

1.2.1 Oil Pump Misuse Hazard: Oil pump misuse can cause rupture or malfunction.

- Read all instruction manuals, tags, and labels before operating the equipment.
- Use the equipment only for its intended purpose. If you are not sure, call your distributor.
- Do not alter or modify this equipment. Use only genuine parts and accessories.
- Check equipment daily. Repair or replace worn or damaged parts immediately.
- Do not exceed the maximum working pressure of the lowest rated component in your system.
- Use fluids and solvents which are compatible with the equipment wetted parts. Refer to the Technical Data section of all equipment manuals. Read the fluid and solvent manufacturer's warnings.
- Do not use 1,1,1-trichloroethane, methylene chloride, other halogenated hydrocarbon solvents, or fluids containing such solvents in pressurized aluminum equipment. Such use could result in a chemical reaction, with the possibility of explosion.
- Handle hoses carefully. Do not pull on hoses to move equipment.
- Route hoses away from traffic areas, sharp edges, moving parts, and hot surfaces.
- Do not lift pressurized equipment.
- Do not move or lift pump during use.
- Comply with all applicable local, state, and national fire, electrical, and safety regulations.

1.2.2 Skin Injection Hazard

Fluid from the dispensing valve, leaks, or ruptured components can inject fluid into your body and cause extremely serious injury, including the need for amputation. Fluid splashed in the eyes or on the skin can also cause serious injury. If a fluid injection injury occurs, GET IMMEDIATE SURGICAL TREATMENT. Do not treat as a simple cut.

- Do not point the dispensing valve at anyone or at any part of the body.

- Do not put your hand or fingers over the end of the dispensing valve.
- Do not stop or deflect leaks with your hand, body, glove or rag.
- Use only extensions and no-drip tips which are designed for use with your dispensing valve.
- Do not use a low pressure flexible nozzle with this equipment.

Follow the Pressure Relief Procedure on page 3 if the dispensing valve clogs before you clean, check or service the equipment.

- Tighten all fluid connections before operating the equipment.
- Check the hoses, tubes, and couplings daily. Replace worn or damaged parts immediately.
- Do not repair high pressure couplings; you must replace the entire hose.

1.2.3 Moving Parts Hazard

Moving parts can pinch or amputate your fingers.

- Do not operate the pump with the air motor plates removed.
- Keep clear of all moving parts when starting or operating the pump.
- Before servicing the equipment, follow the Pressure Relief Procedure to prevent the equipment from starting unexpectedly.

1.2.4 Fire and Explosion Hazard

Improper grounding, poor ventilation, open flames or sparks can cause a hazardous condition and result in a fire or explosion and serious injury.

- Ground the equipment and the object being lubricated. See Grounding below.
- If there is any static sparking or you feel an electric shock while using this equipment, stop dispensing immediately. Do not use the equipment until you identify and correct the problem.
- Provide fresh air ventilation to avoid the buildup of flammable fumes from solvents or the fluid dispensed
- Keep the dispensing area free of debris, including solvent, rags, and gasoline.
- Do not smoke in the dispensing area.

2 Technical data

Pneumatic oil pumps Technical data:

Model	L3950K275
Pressure ratio	5:1
Air inlet max pressure	175 PSI / 12 bar
Oil outlet max pressure	870 PSI / 60 bar
Air motor effective diameter	4.3"
Rated fluid	10.5 GPM / 40L/min

3 Grounding and installation

3.1 Grounding

3.1.1 Warning: Before use the pump, check grounding of the whole system to prevent fire and explosion

3.1.2 To reduce the risk of static sparking, each device should be grounded.

Pump: Use a ground wire and clamp as the Fig.2. Loosen the locknut and place one end of a ground wire on pump ground connection and secure the other end to ground.

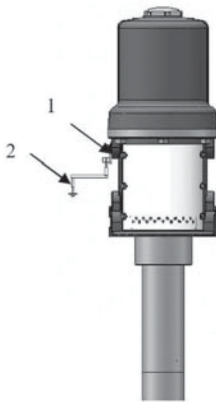

Fig. 2: Grounding guide

Air and Fluid hoses: Use grounded hoses.

Air compressor: Follow manufacturer's recommendations.

Oil control valve: Connect the pump with proper grounding wire, always hold a metal part of the valve firmly to the side of a grounded metal container.

Fluid supply container: Follow the local code.

3.2 Installation

3.2.1 Standard installation

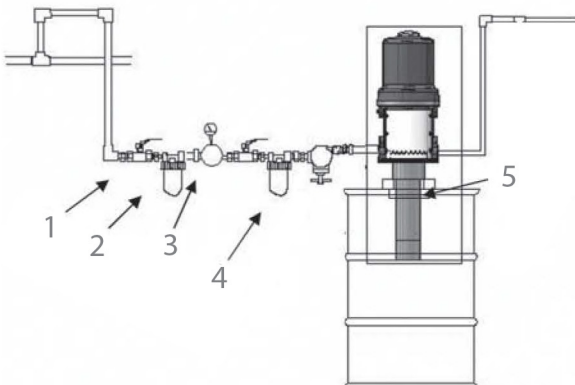

Fig.3: Oil supply system installation

The above installation example is for reference only. Contact your dealer for the components required for your particular installation.

3.2.1.1 Note: Do not hang any device at the air inlet

3.2.1.2 Process

- Put the pump into bung adapter (Fig .3 Parts 5), Install air supply valve (Fig 3. Part 1).
- Install filter (Fig 3. Part 2).
- Install regulator (Fig 3. Part 3).
- Install lubricator (Fig. Part 4).
- Connect oil output.

3.3 Operation

3.3.1 Pressure Relief

3.3.1.1 The system is under pressure until the user manually relieves it. To reduce the risk of serious injury from pressurized fluid, accidental spray from the valve, or splashing fluid, follow this procedure whenever you

- Are instructed to relieve pressure
- Stop dispensing
- Check, clean, or service any system equipment
- Install or clean dispensing devices

3.3.1.2 Pressure Relief procedure

- Turn off the cut-off valve, shut off air
- Direct dispensing valve into suitable grounded waste container, hold metal part of valve against container and open valve to release fluid pressure.

3.3.2 Operation

3.3.2.1 Startup

- While the air regulator is closed, open the air supply valve to the pump.
- Direct dispensing valve into suitable grounded waste container, hold metal part of valve against container and open valve.
- Open air regulator so pump just begins to run. Once the air has been purged from the system, close the dispensing valve.

NOTE: When pump has adequate air supply, and the dispensing valve is open, the pump will run. When the dispensing valve is close, pump will stop.

- Adjust air regulator until you have adequate flow from the dispensing valve. Do not exceed the working pressure of any component in the system.

- Do not allow the pump to run out of the fluid being pumped. If this happens, the pump will cycle very quickly, possibly causing damage. If your pump begins cycling quickly, stop it and check the fluid level in the container. If it is empty, change it, re-prime the system, purging all air before use.

Code	Name
1	Air supply valve
2	Filter
3	Regulator
4	Lubricator
5	Bung adapter

4 Trouble Shooting

Warning:

Before disassembling the pump, check all other possible reasons or solutions to the problem. See troubleshooting table below.

Trouble Shooting

Problem	Cause	Solution
Pump fails to operate	Inadequate air supply pressure or restricted air lines Closed or clogged dispensing valve Clogged fluid lines, hoses, valves, etc Damaged air motor Exhausted fluid supply	Increase air supply; clear Open; clear Clear Service air motor Refill and re-prime or flush
Continuous air exhaust	Worn or damaged air motor gasket, packing, seal, etc.	Service air motor
Erratic pump operation	Exhausted fluid supply Held open or worn intake valve or piston packing Hose damaged	Refill and re-prime or flush Clear; service Change hose
Pump operates, but output low on both strokes	Piston damaged Seal O-ring damaged Hose, valve or other device clogged	Change piston Change O-ring Relieve pressure; clear
Leakage from silencer	O-ring damaged	Change O-ring

WARRANTY*

LEGACY MANUFACTURING COMPANY (“LEGACY”) warrants that this equipment will be free from defects in material and workmanship for a period of five (5) years from the date of purchase, under normal use.* LEGACY’S sole obligation under this warranty is limited to replacing or repairing, free of charge, any equipment that proves to be defective under normal conditions and use according to the recommendations of LEGACY. To obtain repair or replacement, the equipment must be shipped to a LEGACY authorized Warranty and Service Center during the warranty period, transportation charges prepaid, with proof of date of purchase. In the event of repair or replacement, the warranty period shall not be extended beyond the original warranty period.

* If this equipment contains a hose, the hose is warranted for ninety (90) days only. The remaining portions of this equipment are warranted for five (5) years, as described above. While necessary maintenance or repairs on your Legacy equipment can be performed by any company, we recommend that you use only authorized Legacy service centers. Improper or incorrectly performed maintenance or repair voids this warranty. Contact us at service@legacymfg.com or www.legacymfg.com for ordering, installation instructions.